



APR 15 1938

RCA MANUFACTURING COMPANY, INC.

A RADIO CORPORATION OF AMERICA SUBSIDIARY

*Harrison, New Jersey*RCA RADIOTRON  
D I V I S I O NAPPLICATION NOTE No. 90  
April 13, 1938APPLICATION NOTE  
ON  
RESISTANCE-COUPLED AMPLIFIER DATA FOR THE  
6C8-G, 6F8-G, 6J5, 6J5-G, and 6Z7-G

Resistance-coupled amplifier data for the 6C8-G, 6F8-G, 6J5, 6J5-G, and 6Z7-G are given in this Note. The resistance-coupled data are presented in tabular form for easy reference.

Self-bias operation offers several advantages over fixed-bias operation: (1) the effects of possible tube differences are minimized, (2) operation over a wide range of plate-supply voltages without appreciable change in gain is feasible, and (3) the low frequency at which the amplifier cuts off can be easily changed. Fixed-bias operation increases the tendency of an amplifier to motorboat and decreases the compensating action of the plate load resistor.

The values of blocking condenser (C) and cathode-resistor by-pass condenser ( $C_c$ ) were chosen for an output voltage at 100 cycles of 0.8 the value at 420 cycles. A similar cut-off characteristic at any other low frequency ( $f_1$ ) can be obtained by multiplying the capacitance values shown by  $100/f_1$ .

On the chart, the values of  $C_c$  are given for an amplifier with d-c heater excitation. When a-c is used, depending on the character of the associated circuits, the gain, and the value of  $f_1$ , it may be necessary to increase the value of  $C_c$  to minimize hum disturbance.

In some applications, it is desirable to know the value of bias voltage across a cathode resistor specified in the chart. This can be determined easily with the aid of a plate family. For a particular operating condition, draw the load line corresponding to the values of  $R_L$  and  $E_{pb}$  of interest, as shown in Fig. 1A. For each point of intersection of the load line and a bias curve (points a, b, c, etc.), calculate a value of bias resistor ( $R_c$ ). Now, plot a curve (Fig. 1B) showing the relation between calculated values of  $R_c$  and corresponding bias voltages. An ordinate erected at the specified value of  $R_c$  determines the bias.

Copyright, 1938 by  
RCA Manufacturing Co., Inc.AN-90-3-30-38  
Printed in U.S.A.



RESISTANCE-COUPLED TRIODE AMPLIFIER  
USING SINGLE TRIODE OR TWIN-TRIODE TYPE WITH SEPARATE CATHODE TERMINALS

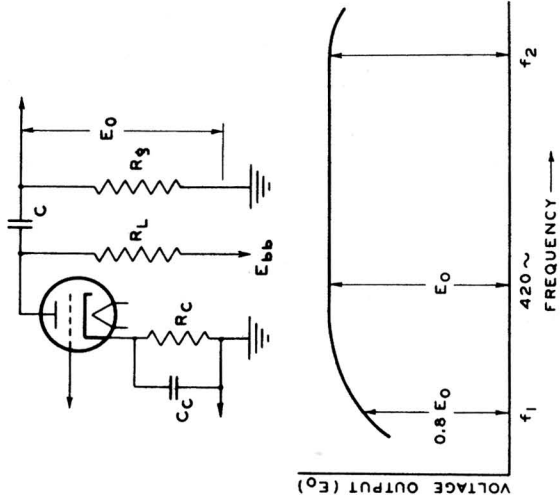

NOTES

- A. Condensers C and Cc have been chosen to give output voltages equal to  $0.8 E_o$  for  $f_1$  of 100 cycles. For any other value of  $f_1$ , multiply values of C and Cc by  $100/f_1$ .
- In the case of condenser Cc, the values shown are for an amplifier with d-c heater excitation. When a-c is used, depending on the character of the associated circuits, the gain, and the value of  $f_1$ , it may be necessary to increase the value of Cc to minimize hum disturbances. It may also be desirable to have a d-c potential difference of approximately 10 volts between heater and cathode.
- B.  $f_2$  = frequency at which high-frequency response begins to fall off.
- C. The voltage output at  $f_1$  for  $n$  like stages equals  $(0.8 E_o)^n$ .
- D. Decoupling filters are not necessary for two stages or less.
- E. For an amplifier of typical construction, the value of  $f_2$  is well above the audio-frequency range for any value of RL.
- F. Always use highest permissible value of Rg.
- G. A variation of  $\pm 10\%$  in values of resistors and condensers has only a slight effect on performance.

RESISTANCE-COUPLED PHASE INVERTER  
USING TWIN-TRIODE TYPE WITH ONE CATHODE TERMINAL

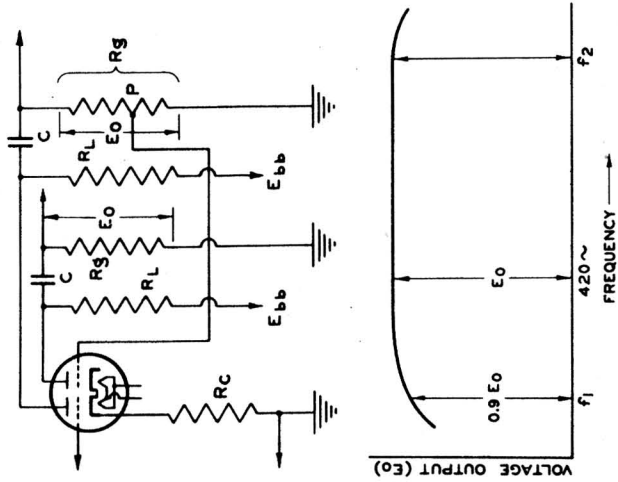

NOTES

The signal input is supplied to the grid of the left-hand triode unit. The grid of the right-hand unit obtains its signal from a tap (P) on the grid resistor (Rg) in the output circuit of the left-hand triode unit. The tap (P) is chosen so as to make the voltage output of the right-hand unit equal to that of the left-hand unit. Its location is determined from the voltage gain values given in the Chart. For example, if the value of voltage gain is 20 (from the Chart), (P) is chosen so as to supply 1/20 of the voltage across (Rg) to the grid of the right-hand triode.

For phase-inverter service, the cathode resistor (Rc) should not be by-passed by a condenser. Omission of the condenser in this service assists in balancing the output voltages. The value of (Rc) is specified on the basis that both units are operating simultaneously at the same values of plate load and plate voltage.



# METHOD OF DETERMINING BIAS VOLTAGE FROM PLATE FAMILY AND LOAD LINE

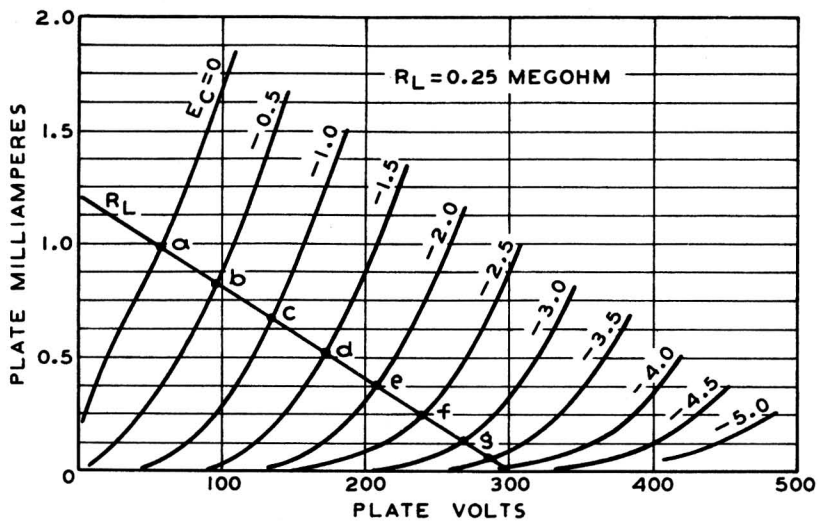

FIG. 1A

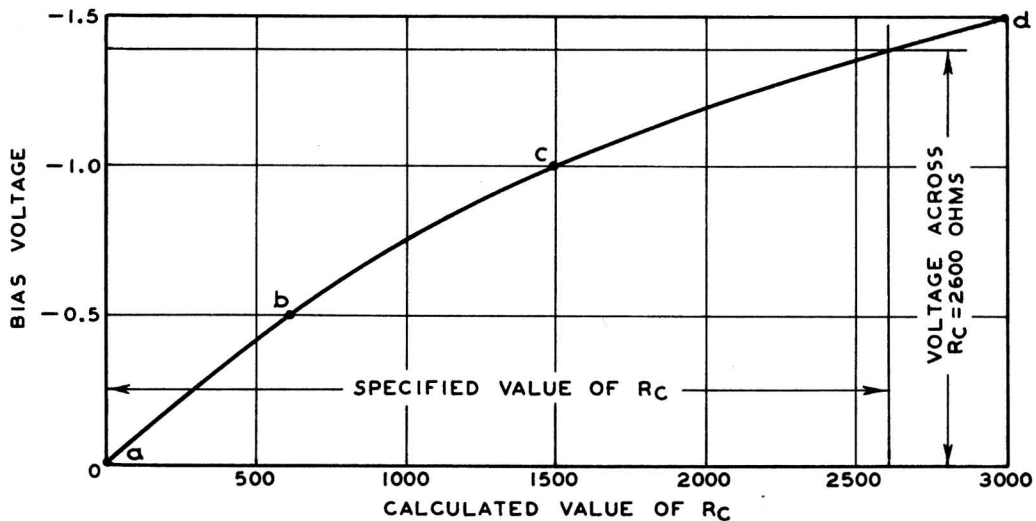

FIG. 1B